

**TONDEUSE AUTOPORTÉE "RIDER"
RIDING MOWER
ZITMAAIER "RIDER"
AUSITZMÄHER "RIDER"
RASAERBA "RIDER"**

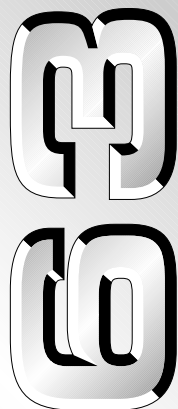

- FR** MANUEL D'UTILISATION
- EN** OPERATOR'S MANUAL
- DE** GEBRAUCHSANWEISUNG
- IT** MANUALE DI ISTRUZIONI
- NL** GEBRUIKERSHANDLEIDING

EMAK PUBBL. 001100902C



71505055/3

INTRODUCTION

Dear Customer,

Thank you for having chosen one of our products. We hope that you will get complete satisfaction from using your new machine and that it will fully meet all your expectations.

This manual has been compiled in order that you may get to know your machine and to be able to use it safely and efficiently. Don't forget that it forms an integral part of the machine, so keep it handy so that it can be consulted at any time and pass it on to the purchaser if you resell the machine.

This new machine of yours has been designed and made in line with current regulations, and is safe and reliable if used for cutting and collecting grass according to the instructions given in this manual (**proper usage**). Using the machine in any other way or ignoring the instructions for safe usage, maintenance and repair is considered "**incorrect usage**" which will invalidate the guarantee and the manufacturer will decline all responsibility, placing the blame with the user for any damage or injury to himself or others in such cases.

Since the product is continually being improved, you may find slight differences between your machine and the descriptions contained in this manual. Certain modifications can be made to the machine without prior warning and without the obligation to update the manual, although the essential safety and function characteristics will remain unaltered. In case of any doubts, do not hesitate to contact your Retailer. And now enjoy your work!

AFTER-SALES SERVICE

This manual gives all the necessary instructions for using the machine and the basic maintenance that may be carried out by the user.

For any information not contained here, contact your Local Retailer or a Licensed Service Centre.

If you wish, your Retailer will be pleased to offer a maintenance programme personalised to your needs. This will enable you to keep your new acquisition in peak performance, maintaining its value.

TABLE OF CONTENTS

1. SAFETY	3
Regulations for using the machine safely	
2. IDENTIFICATION OF THE MACHINE AND COMPONENTS	6
Explanations on how to identify the machine and its main components	
3. UNPACKING AND ASSEMBLY	8
Explanations on how to remove the packing and on how to assemble separated parts	
4. CONTROLS AND INSTRUMENTS	11
Position and functions of all the controls	
5. HOW TO USE THE MACHINE	15
Provides indications for working efficiently and safely	
5.1 Safety recommendations	15
5.2 Why the safety devices cut in	15
5.3 Preliminary operations before starting work	16
5.4 Using the machine	19
5.5 Using on slopes	25
5.6 Transporting	25
5.7 Advice on how to obtain a good cut	26
6. MAINTENANCE	27
All the information for maintaining the machine in peak efficiency	
6.1 Safety recommendations	27
6.2 Routine maintenance	28
6.3 Checks and adjustments	30
6.4 Dismantling and replacement	33
7. TROUBLESHOOTING	35
A help in quickly resolving any problems	
8. ACCESSORIES ON REQUEST	38
A description of the accessories available for particular types of work	
9. SPECIFICATIONS	39
A summary of the main specifications of your machine	

1. SAFETY

1.1 HOW TO READ THE MANUAL

This manual describes various versions of the machine, which mainly differ in:

- the inclusion of components or accessories which may not be available in some areas;
- special equipment fitted.

The symbol  highlights all the differences in usage and is followed by the indication of the version that it refers to.

The symbol “” makes a reference to another part of the manual where further information or clarification can be found.

Some paragraphs in the manual containing information of particular importance for safety and operation are highlighted and signify the following:

NOTE

or

IMPORTANT

These give details or further information on what has already been said, and aim to prevent damage to the machine.

⚠ WARNING!

Non-observance will result in the risk of injury to oneself or others.

⚠ DANGER!

Non-observance will result in the risk of serious injury or death to oneself or others.

NOTE

Whenever a reference is made to a position on the machine “front”, “back”, “left” or “right” side, this is determined by facing the direction of forward travel.

IMPORTANT

For all usage and maintenance operations on the engine or the battery which are not described in this manual, consult the relevant manuals which form an integral part of all the documentation supplied with the machine.

1.2 SAFETY REGULATIONS

(read carefully before using the machine)

A) TRAINING

- 1) Read the instructions carefully. Be familiar with the controls and the proper use of the equipment.
- 2) Never allow children or people unfamiliar with these instructions to use the machine. Local regulations can restrict the age of the operator.
- 3) Never mow while people, especially children, or pets are nearby.
- 4) Bear in mind that the operator or user is responsible for accidents or hazards occurring to other people or their property.
- 5) Do not carry passengers.
- 6) All drivers should seek and obtain professional and practical training which should emphasise:
 - the need for care and concentration when working with the machine;
 - control of a machine sliding on a slope will not be regained by the application of the brake. The main reasons for loss of control are:
 - insufficient wheel grip;
 - being driven too fast;
 - inadequate braking;
 - the type of machine is unsuitable for its task;
 - lack of awareness of the effect of ground conditions, especially slopes;

B) PREPARATION

- 1) While mowing, always wear substantial footwear and long trousers. Do not operate the equipment when barefoot or wearing open sandals.
- 2) Thoroughly inspect the area where the equipment is to be used and remove all objects that can be thrown by the machine.
- 3) **DANGER! Petrol is highly flammable:**
 - store fuel in containers specifically designed for this purpose;
 - refuel outdoors only and do not smoke while refuelling;
 - add fuel before starting the engine. Never remove the cap of the fuel tank or add petrol while the engine is running or when the engine is hot;
 - if petrol is spilled, do not attempt to start the engine but move the machine away from the area of spillage and avoid creating any source of ignition until the petrol vapours have dissipated;
 - replace all fuel tank and container caps securely.

- 4) Replace faulty silencers.

5) Before use, always visually inspect to see that the blade, blade bolts and cutter assembly are not worn or damaged. Replace the worn or damaged blade and bolts in sets to preserve the balance.

C) OPERATION

- 1) Do not operate the engine in a confined space where dangerous carbon monoxide fumes can develop.
- 2) Mow only in daylight or good artificial light.
- 3) Before attempting to start the engine, disengage the blade and shift into neutral.
- 4) Do not use on slopes of more than 10° (17%).
- 5) Remember there is no such thing as a “safe” slope. Travelling on grass slopes requires particular care. To guard against overturning:
 - do not stop or start suddenly when going up or downhill;
 - engage the clutch slowly and always keep the machine in gear, especially when travelling downhill;
 - machine speeds should be kept low on slopes and during tight turns;
 - stay alert for humps, hollows and other hidden hazards;
 - never mow across the face of the slope.
- 6) Stop the blade from rotating before crossing surfaces other than grass.
- 7) Never operate the machine with defective guards, or without safety protective devices in place.
- 8) Do not change the engine governor settings or overspeed the engine. Operating the engine at excessive speed can increase the hazard of personal injury.
- 9) Before leaving the operator’s position:
 - disengage the blade and lower the cutting deck;
 - change into neutral and set the parking brake;
 - stop the engine and remove the key (🔑 in the electric start models);
- 10) Disengage the blade, stop the engine and remove the ignition key (🔑 in the electric start models):
 - before clearing blockages or unclogging chutes;
 - before cleaning, checking or working on the machine;
 - after striking a foreign object. Inspect the machine for any damage and make repairs

before restarting and operating the equipment;
– If the machine starts to vibrate abnormally (inspect it immediately).

11) Disengage the blade when transporting or whenever it is not in use.

12) Stop the engine and disengage the blade:
– before refuelling;

– before removing the grass-catcher.

13) Reduce the throttle setting before stopping the engine.

D) MAINTENANCE AND STORAGE

1) Keep all nuts, bolts and screws tight to be sure the equipment is in safe working condi-

tion.

2) Never store the machine with petrol in the tank inside a building where fumes may reach an open flame or spark.

3) Allow the engine to cool down before storing in any enclosure.

4) To reduce the fire hazard, keep the engine, silencer, battery compartment and petrol storage area free of grass, leaves, or excessive grease.

5) Check the grass-catcher frequently for wear or deterioration.

6) Replace worn or damaged parts for safety.

7) If the fuel tank has to be drained, this should be done outdoors.

8) When the machine is to be stored or left unattended, lower the cutting deck.

1.3 SAFETY LABELS

Your machine must be used with care. Therefore, labels have been placed on the machine to remind you pictorially of the main precautions to take during use.

These labels are to be considered an integral part of the machine.

If a label should fall off or become illegible, contact your Retailer to replace it.

Their meaning is explained below.



1. Warning: Read the Operator's Manual before operating this machine.

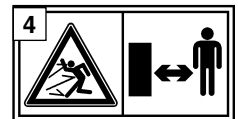

2a. Warning:  in the electric start models: remove the key and read the instructions before carrying out any maintenance or repairs.



2b. Warning:  in the manual start models: disconnect the spark plug cap and read the instructions before carrying out any maintenance or repairs.



3. Danger! Ejected objects: Do not operate without the grass-catcher in place.



4. Danger! Ejected objects: Keep bystanders away.



5. Danger! Machine rollover: Do not use this machine on slopes greater than 10°.

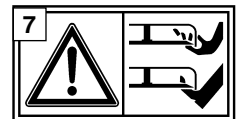

6. Danger! Dismemberment: Make sure that children stay clear of the machine all the time when engine is running.



7. Danger of cutting yourself. Blade in movement. Do not put hands or feet near or under the opening of the cutting plate.

8. Warning: do not manipulate the microswitch.

2. IDENTIFICATION OF THE MACHINE AND COMPONENTS

2.1 IDENTIFICATION OF THE MACHINE

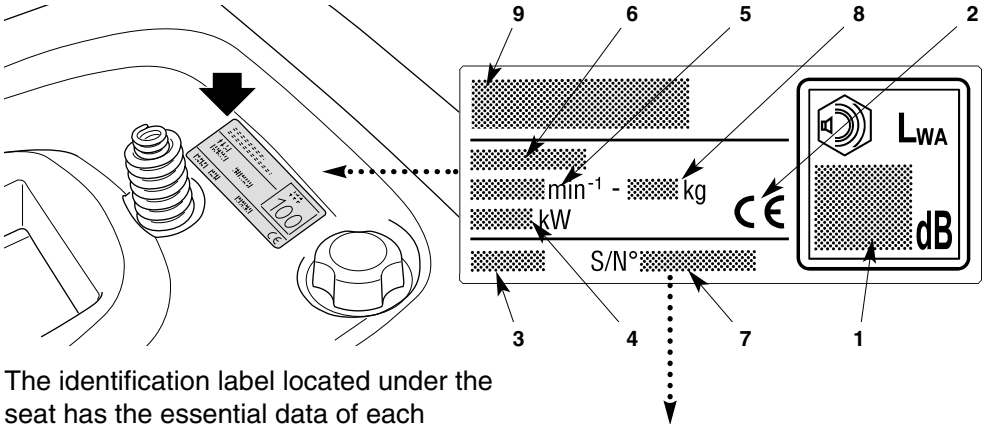

The identification label located under the seat has the essential data of each machine.

The serial number (7) must be quoted when you require technical assistance or spare parts.

Write the serial number of your machine here.

1. Acoustic power level according to directive 2000/14/CE
2. Conformity mark according to directive 98/37/EEC
3. Year of manufacture
4. Nominal power (if indicated)
5. Operating engine speed in r.p.m
6. Type of machine
7. Serial number
8. Weight in kg
9. Name and address of Manufacturer

2.2 NAME AND ADDRESS OF MANUFACTURER

The machine is composed of a series of main components that have the following functions:

11. **Cutting deck:** this is the guard enclosing the rotating blade.
12. **Blade:** this is what cuts the grass. The wings at the ends help convey the cut grass towards the collector channel.

13. **Collector channel:** this is the part connecting the cutting deck to the grass-catcher.
14. **Grass-catcher:** as well as collecting the grass cuttings, this is also a safety element in that it stops any objects drawn up by the blade from being thrown outside of the machine.
15. **Engine:** this moves the blade and drives the wheels. Its specifications and regulations for use are described in a specific manual.
16. **Batteria** (▶ *only in the electric start models*): provides the energy for starting the engine. Its specifications and regulations for use are described in a specific manual.
17. **Driver seat:** this is where the machine operator sits. It has a sensor which detects the presence of the operator and acts as a safety device.
18. **Labels for regulations and safety:** give reminders on the main provisions for working safely, each of which is explained in chapter 1.
19. **Engine cover:** for access to the engine

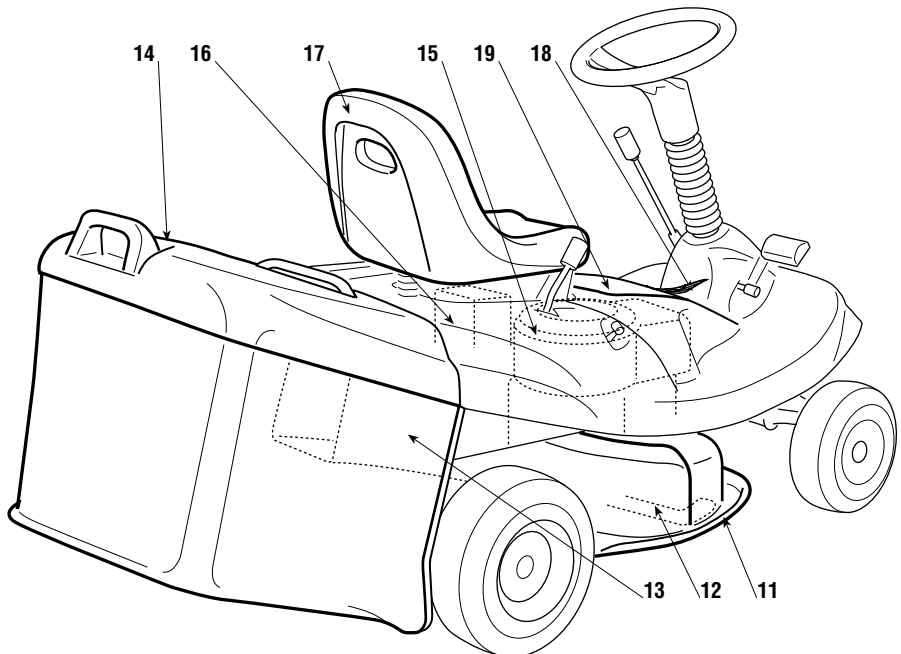

3. UNPACKING AND ASSEMBLY

IMPORTANT

The machine is supplied without engine oil or fuel. Before starting up the engine, fill with oil and fuel following the instructions given in paragraph 5.3.3. and in the engine manual.

For storage and transport reasons, some components of the machine have to be assembled after their removal from the packing. Final assembly is carried out by following these simple instructions.

3.1 UNPACKING

When unpacking the machine, take care to gather all the individual parts, fittings and documentation.

NOTE

o avoid damaging the cutting deck when getting the machine down from the pallet, take it to the maximum height and be very careful.

The supply includes:

- bolts and screws, necessary for completing the assembly
- a syringe for draining the engine oil

In addition (▶ **in the electric start models**):

- a battery charger
- 2 starter keys
- a spare 6.3 A fuse, to be kept in case of necessity.

3.2 FITTING THE STEERING WHEEL

Put the machine on a flat surface and straighten up the front wheels.

1. fit the bellows (1) onto the column (2);
2. fit the steering wheel and its column (2) onto the protruding shaft (3) and fasten it with the screws (4) and nuts (5) supplied, using both holes on the shaft (3).

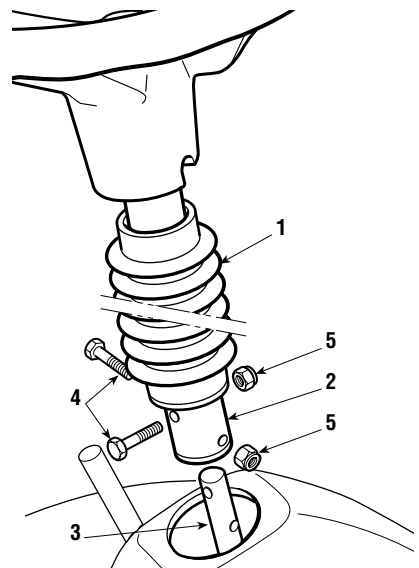

3.3 FITTING THE SEAT

1. Fit the seat (1) onto the plate (2) using the screws (3).

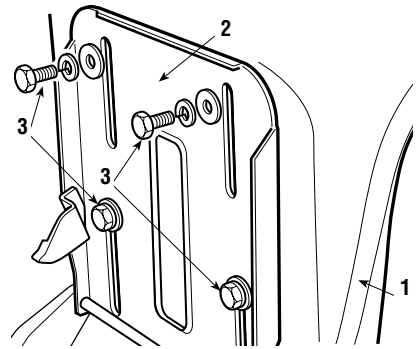

3.4 FITTING THE BLADE ENGAGEMENT LEVER

1. Fit the end of the lever (1) on the projecting part of the pin (2) and fix it all by tightening the screw (3) and nut (4).

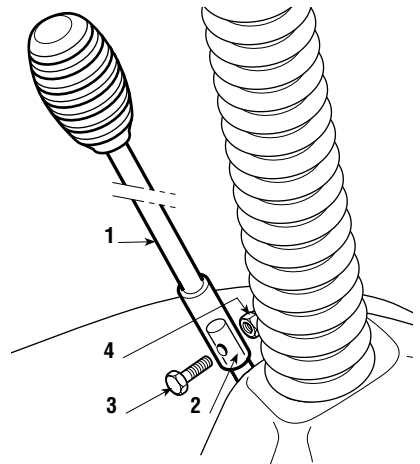

3.5 CONNECTING THE BATTERY (▶ *only in the electric start models*):

- The battery (1) is situated under the seat.
- 1. Connect the battery connector (2) to the machine connector (3);
- 2. recharge the battery by following the instructions in the manual (▶ 6.2.5).

IMPORTANT

Never start the engine until the battery is fully charged!

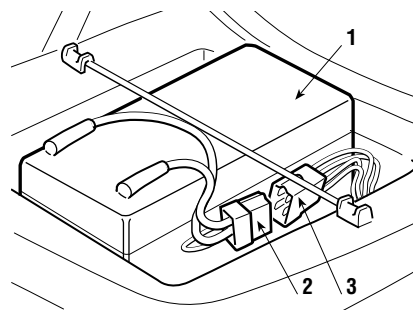

⚠ WARNING!

Follow the battery manufacturer's instructions regarding safe handling and disposal.

3.6 FITTING THE GRASS-CATCHER

Identify the screws to be used by following the drawing that shows them in their actual size.

1. Fit the upper frame (1) in the upper slots (2) of the canvas cover (3);
2. join the two pieces of the frame (1) and (4) using the screws (5). Fit the two tie rods (6) and fasten them by using the screws (7);
3. hook the plastic profiles (8) onto the front frame tubes (4) with the aid of a screwdriver (9).
4. insert the handle (10) into the holes of the cover (11) and attach this to the frame using the screws (12);
5. fit the rear handle (13) and fasten it with the screws (14).

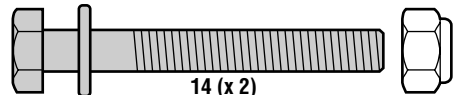
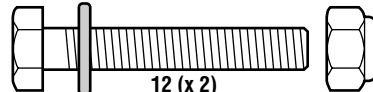
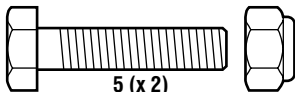
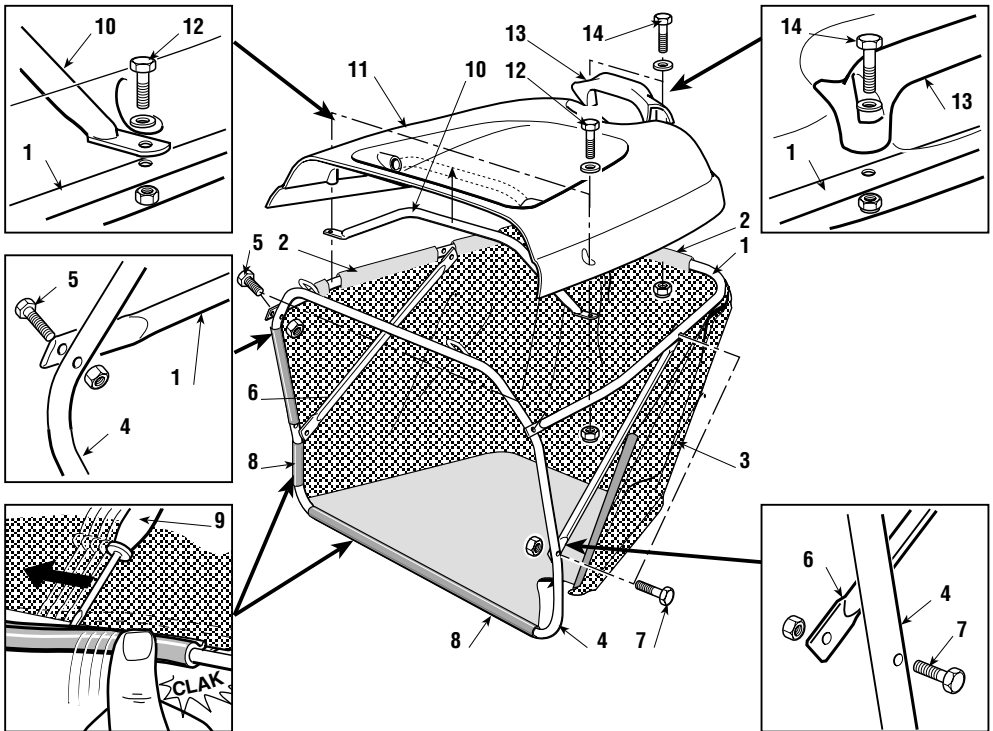

4. CONTROLS AND INSTRUMENTS

4.1. STEERING WHEEL

Turns the front wheels.

4.2 CLUTCH / BRAKE PEDAL

This pedal has a double function: during the first part of its travel it acts as a clutch, engaging and disengaging drive to the wheels, and in the second part it works the brake.

IMPORTANT Do not keep the pedal half way of clutch engagement or disengagement, as this can cause overheating and damage the transmission belt.

NOTE When the machine is in movement, keep your foot off the pedal.

4.3 PARKING BRAKE LEVER

This lever stops the machine from moving when it has been parked. There are

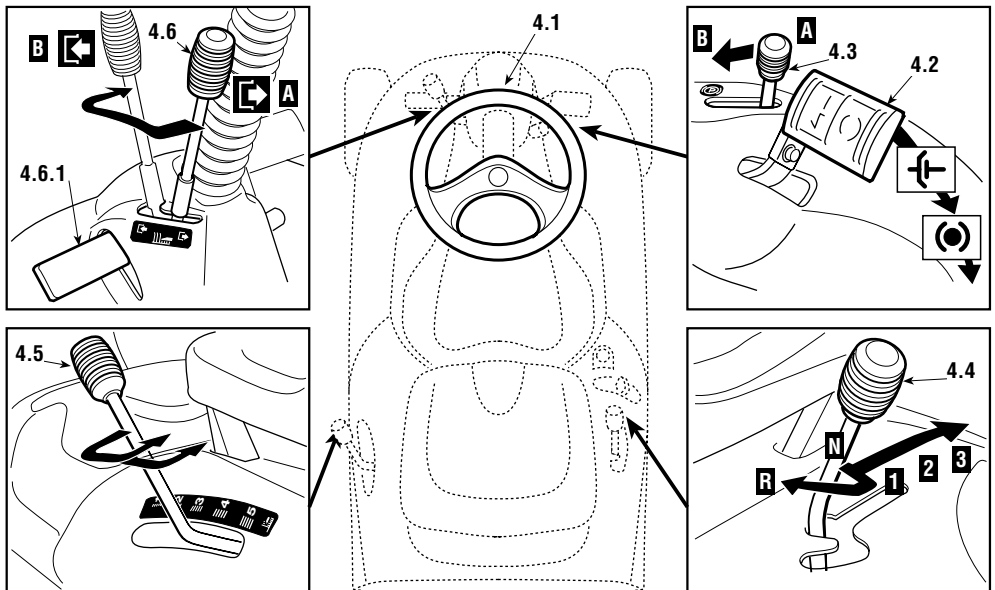

two positions:

- «A» = Brake off
- «B» = Brake engaged

- The brake is engaged by pressing the pedal (4.3) right down and moving the lever to position «B». When you take your foot off the pedal it will be blocked by the lever in the down position.
- To disengage the parking brake, press the pedal (4.3). The lever will return to position «A».

4.4 SPEED CHANGE LEVER

This lever has five positions for the three forward gears, the neutral position «N», and reverse «R».

- To change gear, press the pedal (4.3) halfway down and move the lever as per the indications on the label.

⚠ WARNING!

Reverse must be engaged when the machine has stopped.



4.5 CUTTING HEIGHT ADJUSTING LEVER

There are five positions for this lever, shown as «1» to «5» on the plate, which correspond to various cutting heights from 3 to 7.5 cm.

- To go from one position to another, move the lever sideways and put it back in one of the stop notches.

4.6 LEVER ENGAGEMENT AND BRAKE OF BLADE

The lever has two positions, as shown on the plate:

-  «A» = Blade disengaged
-  «B» = Blade engaged

- If the blade is engaged when safety conditions have not been complied with, the engine shuts down and cannot be restarted (☛ 5.2).
- In disengaging the blade (Pos. «A»), a brake is simultaneously activated which stops their rotation within a few seconds.

▶ Only for machines with Tecumseh engine:

- The blade can only be engaged by pressing the pedal (4.6.1) right down; when
- the pedal is released, the lever automatically returns to position «A», disengag-
- ing the blade.
-

► In the electric start models

4.11 KEY IGNITION SWITCH

This key operated control has three positions:

- «OFF» everything is switched off;
- I «ON» activates all parts;
- ⓪ «START» engages the starter motor.

On being released at the «START» position, the key will automatically return to «ON».

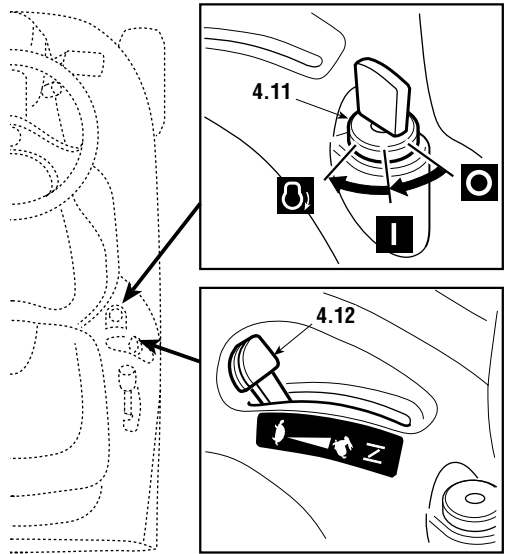

4.12 ACCELERATOR LEVEL

Regulates the engine's r.p.m. The positions are indicated on a plate showing the following symbols:

- ⓪ «CHOKE» starting from cold
- ⤴ «SLOW» for minimum engine speed
- ⤵ «FAST» for maximum engine speed

- The «CHOKE» position enriches the mixture so must only be used for the time necessary when starting from cold.
- When moving from one area to another, put the lever in a position between «SLOW» and «FAST».
- When cutting, go to the «FAST» position.

► In the manual start models

4.21 PULL START HANDLE

To start the engine, take the starter cable handle and give it a firm tug.



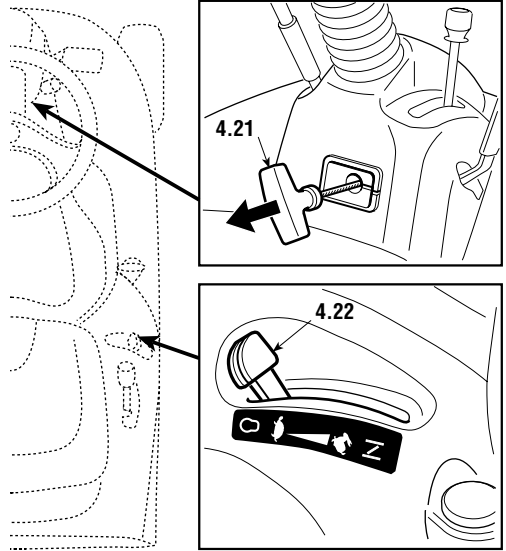

- Then put the handle back in its seat, guiding the cable as it automatically rewinds.



4.22 ACCELERATOR LEVEL

It regulates the rpm and stops the engine.

The positions are indicated on the plate showing the following symbols:

	«OFF»	for switching off the engine
	«CHOKE»	starting from cold
	«SLOW»	for minimum engine speed
	«FAST»	for maximum engine speed

- The «CHOKE» position enriches the mixture so must only be used for the time necessary when starting from cold.
- When moving from one area to another, put the lever in a position between «SLOW» and «FAST».
- When cutting, go to the «FAST» position.

5. HOW TO USE THE MACHINE

5.1 SAFETY RECOMMENDATIONS

⚠ DANGER! *The machine must only be used for the purpose for which it was designed (cutting and collection of grass).*

Do not tamper with or remove the safety devices fitted to the machine.

REMEMBER THAT THE USER IS ALWAYS RESPONSIBLE FOR DAMAGE AND INJURIES TO OTHERS. Before using the machine:

- *read the general safety regulations (☛ 1.2), paying particular attention to driving and cutting on slopes;*
- *carefully read the instructions for use, become familiar with the controls and on how to quickly stop the blade and engine.*
- *never put your hands or feet next to or beneath the rotating parts and always keep away from the discharge opening.*

Do not use the machine when in a precarious state of health or under the effect of medicines or other substances that can reduce your reflex actions and your ability to concentrate.

It is the user's responsibility to assess the potential risk of the area where work is to be carried out, as well as to take all the necessary steps to ensure his own safety and that of others, particularly on slopes or rough, slippery and unstable ground.

Do not leave the machine stopped on high grass with the engine running to avoid the risk of starting a fire.

Always lower the speed when changing direction, especially on tight turns.

⚠ WARNING! *This machine must not be used on slopes greater than 10° (17%) (☛ 5.5).*

IMPORTANT

All the references relating to the positions of controls are those described in chapter 4.

5.2 WHY THE SAFETY DEVICES CUT IN

The safety devices work in two ways:

- by preventing the engine from starting if all the safety requirements have not been met;
- by stopping the engine if even just one of the safety requirements is lacking.

- a)** The engine must only be started in the following conditions:
- the transmission is in “neutral”;
 - the blade is not engaged;
 - the operator is seated or the parking brake is engaged. (▶ **Only for machines with B&S engine**)

- b)** The engine stops when:
- the operator leaves his seat when the blade is engaged;
 - the operator leaves his seat with a gear engaged;
 - the grass-catcher is lifted without disengaging the blade;
 - the blade is engaged without the grass-catcher in place;
 - the parking brake is engaged without disengaging the blade. (▶ **Only for machines with B&S engine**)

5.3 PRELIMINARY OPERATIONS BEFORE STARTING WORK

These controls ensure that the work gives the best results and is done in maximum safety.

5.3.1 SEAT ADJUSTMENT

Adjust the seat by sliding it along the bracket slots.

1. Loosen the four screws (1);
2. once you have found the right position, securely tighten the four screws (1).

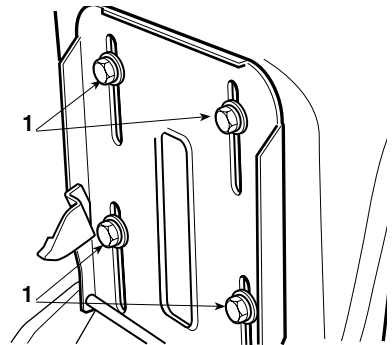

5.3.2 TYRE PRESSURE

Having the correct tyre pressure is essential for ensuring that the cutting deck is perfectly horizontal and thus mows evenly.

1. Unscrew the valve caps;
2. connect a compressed air line with a gauge to the valves and check that the pressure is:
 - Front tyres 1.8 bar
 - Rear tyres 1.3 bar
3. screw the valve caps back on.

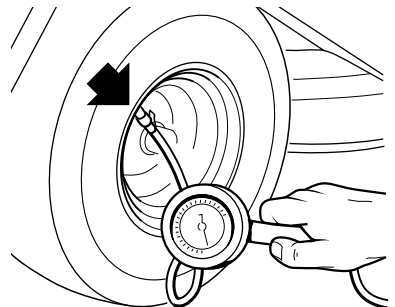

5.3.3 FILLING WITH OIL AND FUEL

⚠ DANGER! *Refuelling should be carried out in an open or well-ventilated area with engine stopped. Always remember that petrol fumes are inflammable. DO NOT TAKE A NAKED FLAME TO THE TANK'S OPENING IN ORDER TO SEE THE TANK'S CONTENTS AND DO NOT SMOKE WHEN REFUELLING.*

NOTE *The type of oil and fuel to be used is given in the engine manual.*

With the engine stopped, check its oil level.

1. to reach the plug (1), remove the engine cover (2) with the aid of a screwdriver;
2. by closely following the methods described in the engine manual, make sure the oil level is between the MIN and MAX marks on the dipstick (3);
3. always refit the plug (1) and engine cover (2).

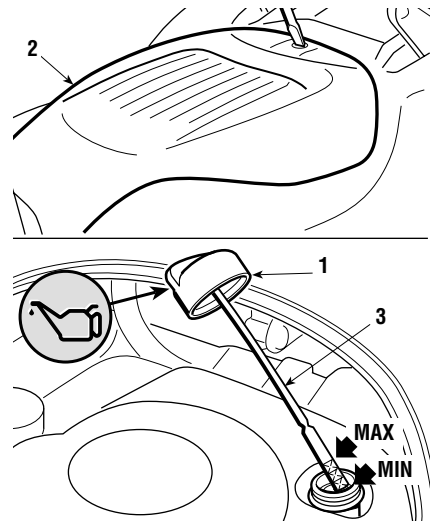

To refuel (to be done when the machine has stopped):

1. unscrew the plug (4) from the tank located behind the seat;
2. refuel using a funnel, but do not completely fill the tank. The tank's capacity is about 3.5 litres;
3. always refit the plug (4).



IMPORTANT *Do not drip petrol onto the plastic parts to avoid ruining them. In the event of accidental leaks, rinse immediately with water.*

5.3.4 FITTING THE PROTECTIONS AT THE EXIT (GRASS CATCHER)

⚠ WARNING! *Never use the machine without having fitted the exit protection!*

Hook the grass-catcher (1) onto the brackets (2) and centre it up with the rear plate, so that the two reference marks (3) coincide.

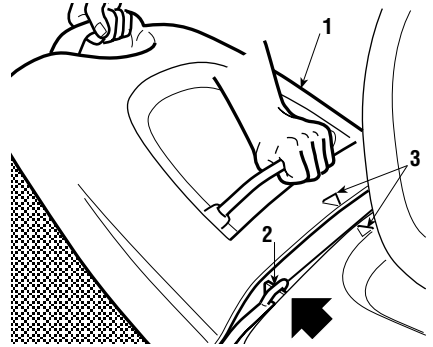

5.3.5 CHECKING THE EFFECTIVENESS OF THE SAFETY DEVICES

Check that the safety systems are working properly by simulating the various situations of usage (☛ 5.2) and by making sure that the correct result is achieved for each situation.

If the check shows any deficiencies, consult a Licensed Service Centre immediately.

5.3.6 CHECKING THE BRAKING SYSTEM

Make sure that the machine's braking capacity is adequate for the conditions of usage. Avoid starting the machine if you have doubts on the brake efficiency.

If necessary, adjust the brake (☛ 6.3.4) and if you still have doubts on its efficiency, consult a Licensed Service Centre

5.3.7 CHECKING THE BLADE

⚠ WARNING! *Wear strong gloves when handling the blade.*

Check that the blade is sharpened properly and firmly fixed to the bracket.

- A badly sharpened blade pulls at the grass and causes the lawn to turn yellow.
- A loose blade causes unusual vibrations and can be dangerous.

If the check shows any problems, sharpen or fasten the blade properly (☛ 6.3.1).

5.4 USING THE MACHINE

5.4.1 STARTING THE ENGINE

⚠ DANGER! *All starting operations have to be effected in an open or well-ventilated area! ALWAYS REMEMBER THAT EXHAUST GASES ARE TOXIC!*

To start the engine:

1. sit on the seat and press the brake pedal right down (☛ 4.3);
2. put the transmission into neutral («N») (☛ 4.4);
3. disengage the blade (☛ 4.6);
4. when starting from cold, put the accelerator lever in the «CHOKE» position shown on the label (☛ 4.12 - 4.22). Alternatively, if the engine is still hot, position the lever between «SLOW» and «FAST»;

☛ In the electric start models

- 5. put in the key (☛ 4.11) and turn to «ON» to make electrical contact, then
- turn to «START» to start the engine;
- 6. release the key once the engine has started;

☛ In the manual start models

- 5. take the starter cable handle (☛ 4.21) and firmly tug it.
- 6. once the engine has started, put the handle back in its seat.

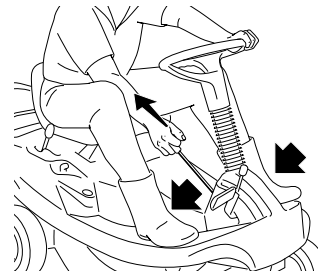

7. After the machine has run for a few seconds, put the accelerator lever on «START» and then on «SLOW».

IMPORTANT

the choke must be closed as soon as possible. Using it when the engine is already warm can foul the spark plugs and cause the engine to run erratically.

NOTE

If you have difficulty starting, do not make several attempts to avoid flooding the engine or running down the battery (if present).

- Check that the conditions allowing the engine to start are met
- Turn the key (☛ **electric start**) or the accelerator (☛ **manual start**) to «OFF». Wait for a few seconds and repeat the start operation. Should the

malfunction persist, refer to chapter «7» of this manual and the engine manual.

5.4.2 STARTING AND MOVING WITHOUT MOWING

⚠ WARNING! *This machine has not been approved for use on public roads. It has to be used (as indicated by the highway code) in private areas closed to traffic.*

NOTE *When moving the machine, the blade must be disengaged and the cutting deck put at its highest position (position «5»).*

To start the forward movement:

1. put the accelerator control between the «SLOW» and «FAST» positions;
2. push the pedal right down (☛ 4.2) and put the gear change lever in 1st gear (☛ 4.4).
3. release the pedal gradually to begin the movement.

Reach the desired operating speed using the accelerator and gear lever. To change gear, the clutch must always be used by pushing the pedal (☛ 4.2).

⚠ WARNING! *The pedal must be released gradually as sudden engagement may cause tipping up and loss of control of the vehicle.*

5.4.3 BRAKING

To brake:

1. first slow down the machine by reducing the engine speed;
2. push the pedal right down (☛ 4.2) to lower the speed even more until the machine stops.

5.4.4 REVERSE

Reverse **MUST** be engaged only when the machine has stopped.

The reverse is engaged in the same way as above (☛ 5.4.2), by moving the lever sideways and putting it into position «R».

5.4.5 GRASS CUTTING

IMPORTANT

The machine is not designed for heavy-duty use or for mowing large quantities of grass.



IMPORTANT

The blade is engaged by means of a clutch device. To avoid damage or premature wear of the friction elements, strictly observe the following instructions.

To start cutting:

1. remove any foreign objects that could be hit by the blade (stones, branches, bones, wire etc.) and mark off the position of hidden elements that cannot be moved (roots, sprinklers etc.);
2. check that the grass-catcher is fitted properly;
3. put the accelerator lever into the «FAST» position;
4. bring the cutting deck to the highest position before engaging the blade;
5. engage the blade (➡ 4.6) without remaining in the midway positions, whilst staying away from high grass;
6. start moving forwards onto the grass area very gradually and with particular caution, as already described;
7. on rough ground, adjust the cutting height to prevent the blade from knocking against uneven ground or foreign objects, damaging the blade and bracket;
8. engage the most suitable gear in order to reach the desired forward speed (1st - 2nd gear) and adjust the cutting height (➡ 4.5) so that the quantity of grass to be removed is not too much that it jams the blade or clogs up the collector channel.

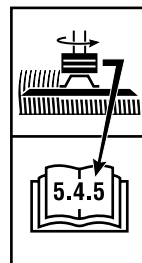

⚠ WARNING!

When cutting on sloping ground, the forward speed

must be reduced to ensure safe conditions (☛ 1.2 - 5.5).

- Lower the speed whenever you note a reduction in engine speed, since a forward speed that is too fast compared to the amount of grass being cut will never mow the grass well.
- Disengage the blade and put the cutting deck in the highest position whenever you need to get past an obstacle or a hump.
- Use the 3rd gear only when moving the machine from one area to the other.

5.4.6 EMPTYING THE GRASS-CATCHER

The grass-catcher is full when the grass cuttings remain on the lawn. If you continue mowing with the grass-catcher full, it may block the collector channel.

To empty the grass-catcher:

1. lower the engine speed;
2. go into neutral (N) (☛ 4.4) and stop the machine's forward movement;
3. disengage the blade (☛ 4.6);
4. engage the parking brake on slopes;
5. hold onto the rear handle and tip up the grass-catcher to empty it;

NOTE

This operation can only be done with the blade disengaged, otherwise the engine stops.

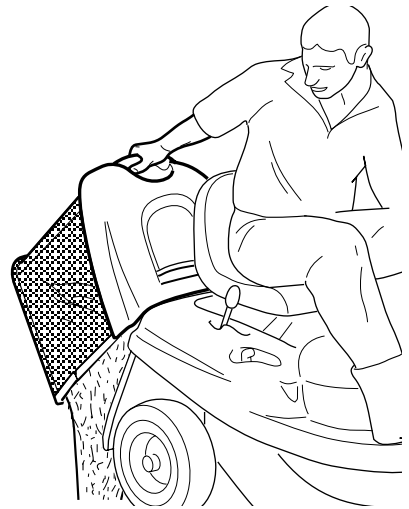

5.4.7 UNBLOCKING THE COLLECTOR CHANNEL

⚠ WARNING!

This job must only be performed with the engine turned off.

If the collector channel gets blocked (due to accumulated grass cuttings filling up the grass-catcher or an excessively high speed with relation to the quantity of grass cuttings), you need to:

1. stop forward movement immediately, disengage the blade and stop the engine;
2. remove the grass-catcher;
3. remove the accumulated cuttings, reaching them from the exit of the collector channel.

5.4.8 END OF MOWING

When you have finished mowing, disengage the blade, lower the engine speed and ride the machine with the cutting deck in the highest position.

5.4.9 END OF WORK

Once you have finished mowing, stop the machine and engage the parking brake.

► ***In the electric start models:***

- 1. shift the accelerator lever to «SLOW»;
- 2. switch off the engine by turning the key to «STOP»;

• **⚠ WARNING!** *Always take out the ignition key before leaving the machine unattended!*

• **IMPORTANT** *To keep the battery charged, do not leave the key in the «ON» position when the engine is not running.*

► ***In the manual start models:***

- 1. shift the accelerator lever to «OFF».

• **⚠ WARNING!** *Always make sure that the accelerator level is in the «OFF» position before leaving the machine unattended!*

5.4.10 CLEANING AND STORAGE

⚠ WARNING! *Always empty the grass-catcher and do not leave containers full of cut grass inside a room.*

After each mowing, clean the outside of the machine, empty the grass-catcher and shake it to remove residual grass and earth.

Clean the plastic parts of the body with a damp sponge using water and detergent, taking care not to wet the engine, the electrical parts or the electronic card.

IMPORTANT *Never use hose nozzles or harsh detergents for cleaning the body and engine!*

For washing the inside of the cutting deck and the collector channel the machine

must be on firm ground:

1. fit the grass-catcher;
2. connect a water hose to its pipe fitting (1), and run water through it;
3. sit at the operator's position;
4. lower the cutting deck completely;
5. start the engine and stay in neutral;
6. engage the blade and leave it to turn for a few minutes.

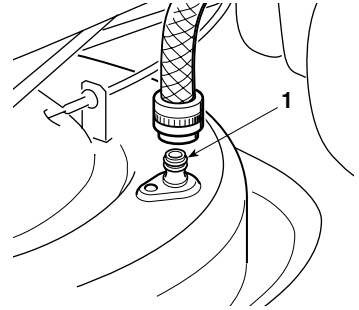

Take off the grass-catcher, empty and rinse it, then put it in a position where it can dry quickly.

Put the machine away in a dry place protected from the weather and, if possible, cover it with a cloth.

5.4.11 INACTIVITY FOR LONG PERIODS

⚠ WARNING! *Carefully remove any dry grass cuttings which may have collected around the engine or silencer to prevent their catching fire the next time the machine is used!*

If the machine is likely to be unused for a long period (more than 1 month), follow the instructions in the engine manual. Lubricate all joints as indicated (☛ 6.2.1).

➤ *In the electric start models:*

-
- Disconnect the connectors (2 and 3) of the battery (1).
-
-

IMPORTANT *The battery must be kept in a cool and dry place. Before a long storage period (more than 1 month), always charge the battery, and then recharge before using again (☛ 6.2.5).*

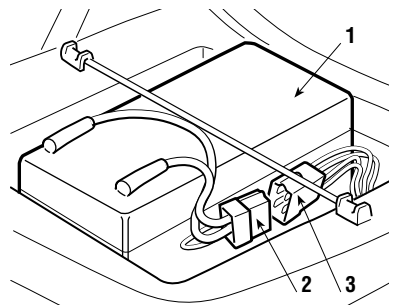

Empty the fuel tank by disconnecting the tube situated at the inlet of the fuel filter

(1) and reached by the right-hand side above the collector channel. Then remember to reconnect the tube.

The next time the machine is used, check that there are no fuel leaks from the tubes or carburettor.

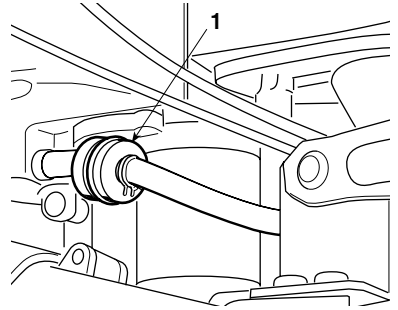

5.5 USING ON SLOPES

When mowing lawns on a slope, observe the maximum gradients already mentioned (**max 10° - 17%**) and move up and down but never across them. Take great care when changing direction that the highest wheels do not hit obstacles (such as stones, branches, roots, etc.) that may cause the machine to slide sideways, tip over or otherwise cause loss of control.

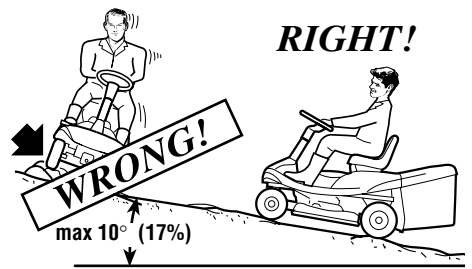

⚠ DANGER!

SLOW DOWN BEFORE CHANGING DIRECTION ON

SLOPES. Never use reverse to reduce speed going downhill: you may lose control of the machine, particularly on slippery surfaces. Never ride the machine on slopes in neutral or with the clutch out! Always engage a low gear and the parking brake before leaving the machine at a stopped and unattended.

⚠ WARNING!

Take care when beginning forward movement on sloping ground to prevent the risk of tipping up. Reduce the forward speed before going on a slope, particularly downhill.

5.6 TRANSPORTING

⚠ WARNING!

If the machine is transported on a truck or trailer, use suitable equipment for lifting and an appropriate number of people for the weight involved and the type of lifting system used. The machine must

never be lifted by rope and tackle. During transport, lower the cutting deck, engage the parking brake and fasten the machine securely to the hauling device with ropes or chains.

5.7 ADVICE ON HOW TO OBTAIN A GOOD CUT

1. To keep a lawn green and soft with a good appearance, it should be cut regularly without damaging the grass.
2. It is always better to cut the grass when dry.
3. The blade must be in good condition and well sharpened so that the grass is cut straight without any ragged edge that leads to yellowing at the ends.
4. The engine must run at full speed, both to ensure a sharp cut of the grass and to get the necessary thrust to push the cuttings through the collector channel.
5. The frequency of mowing should be in relation to the rate of growth of the grass, which should not be left to grow too much between one cut and the next.
6. During hot and dry periods, the grass should be cut a little higher to prevent the ground from drying out.
7. If the grass is very tall, it should be cut twice in a twenty-four hour period. The first time at maximum cutting height, possibly reducing the cutting width and the second cut at the height desired.
8. The appearance of the lawn will improve if you alternate the cutting in both directions.
9. If the collector channel tends to get blocked with grass, you should reduce the forward speed since this may be too high for the condition of the lawn. If the problem persists, the probable causes are either the badly sharpened blade or deformed wings.
10. Be very careful when mowing near bushes or kerbs since these could distort the horizontal position of the cutting deck, and damage its edge as well as the blade.

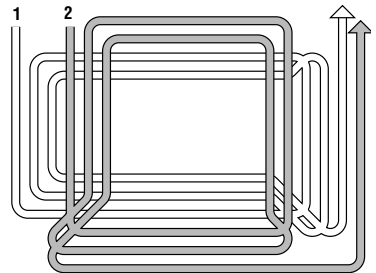

6. MAINTENANCE

6.1 SAFETY RECOMMENDATIONS

⚠ WARNING! *Disconnect the spark plug cap, remove the key (▶ in the electric start models) or shift the accelerator lever to «OFF» (▶ in the manual start models) and read the relevant instructions before starting any cleaning, maintenance or repairs. Wear suitable clothing and strong gloves for dismantling and refitting the blade and in all other hazardous situations for the hands.*

⚠ WARNING! *Never use the machine with worn or damaged parts. Faulty or worn-out parts must always be replaced and not repaired. Only use genuine spare parts: those that are not of an equivalent quality may damage the machine or endanger the safety of yourself and others.*

IMPORTANT *Never get rid of used oil, fuel or other pollutants in unauthorised places!*

6.1.1 LIFTING THE LIFT VERTICALLY

In order to have easy access to the lower part of the machine, you can lift it vertically.

⚠ WARNING! *Place the machine on firm and flat ground. At least two competent people should be involved in this operation to assure the necessary safety.*

1. Empty the fuel tank;
2. bring the cutting deck to position «5»;
3. insert a block (1) about 60 mm long underneath the rear plate, taking care to position it between the edge of the plate and the exit of the collector channel;
4. lift the machine from the front, holding onto parts that offer a firm grip (apart from the steering wheel) and rest it on the points shown, taking care not to damage the grass-catcher's brackets.

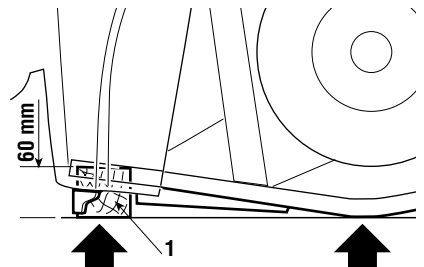

⚠ DANGER! *Be sure of the good stability of the machine before car-*

rying out any type of work on it and avoid operations which may cause it to fall over.

6.2 ROUTINE MAINTENANCE

6.2.1 MAINTENANCE AND GENERAL LUBRICATION

Follow the diagram showing the points requiring checks, lubrication and routine maintenance, together with the type of lubricant to be used and the frequency required.

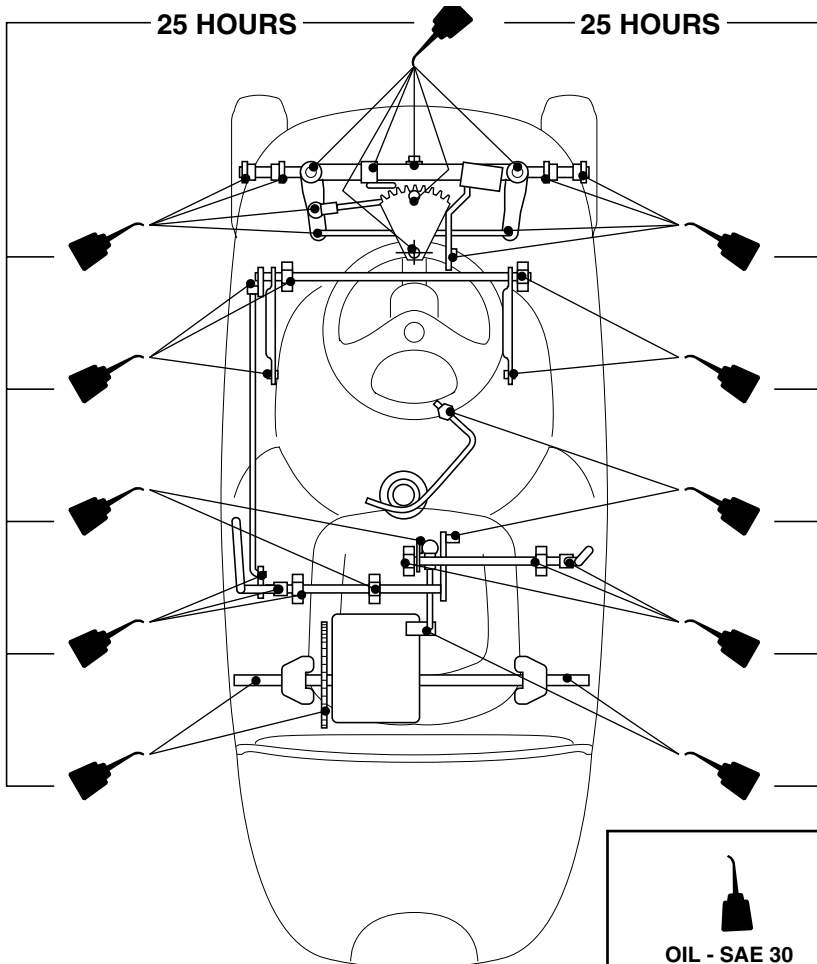

6.2.3 ENGINE

Follow all the instructions in the engine manual.

To drain the engine oil:

1. unscrew the topping up cap (1);
2. fit the pipe (2) onto the syringe (3) and insert it right into the hole;
3. using the syringe (3), suck up all the engine oil, bearing in mind that you need to repeat this operation a few times before all the oil is removed.

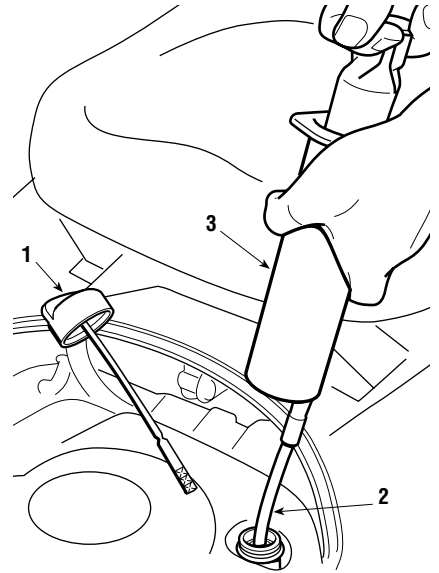

6.2.4 GEAR LEVER AND DIFFERENTIAL

These are sealed single units which do not require maintenance. They are permanently lubricated and this lubricant does not need changing or topping up.

6.2.5 BATTERY (▶ *Only in the electric start models*)

- To ensure long life to the battery it is essential to keep it carefully maintained.
- The machine battery must always be charged:
 - – before using the machine for the first time after purchase;
 - – before leaving the machine for a prolonged period of disuse;
 - – before starting up the machine after a prolonged period of disuse.
-
- – To ensure long life to the battery it is essential to keep it carefully maintained. Failure in following the procedure or in charging the battery could permanently damage the battery elements.
- – A flat battery **must** be recharged as soon as possible.
-
-
-
-
-

IMPORTANT

*Recharging must be done using a battery charger at **constant voltage**. Other recharging systems can irreversibly damage the battery.*

The machine has a connector (1) for recharging located next to the battery,

- which is to be connected to the corresponding connector of the special “CB02” maintenance battery charger supplied.

IMPORTANT

This connector must only be used for connecting to the “CB02” maintenance battery charger. For its use:

- *follow the instructions given in the relative instructions manual;*
- *follow the instructions given in the battery manual.*

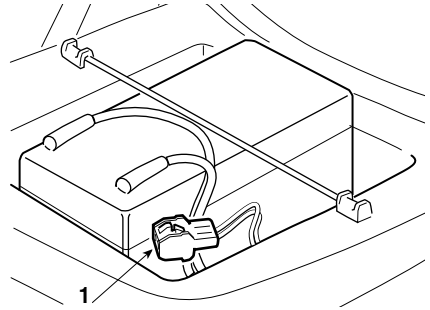

6.3 CHECKS AND ADJUSTMENTS

6.3.1 DISMANTLING, SHARPENING AND BALANCING THE BLADE

A badly sharpened blade tears at the grass, reduces collection and makes the lawn turn yellow. To dismantle the blade, hold onto it tightly using work gloves and loosen the two screws (1).

Sharpen the two cutting edges using a medium grade grinding wheel and check the balance by holding the blade up with a round 18 mm Ø bar inserted in the central hole.

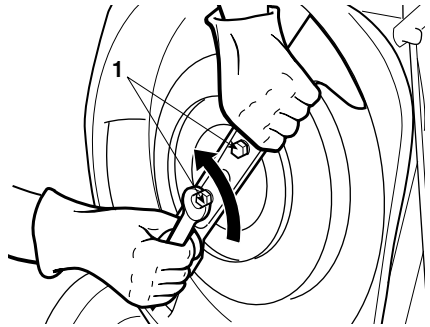

⚠ WARNING! *Always replace the damaged or bent blade; never try to repair it! ALWAYS USE MANUFACTURER'S GENUINE REPLACEMENT BLADES BEARING THE SYMBOL ⚠!*

⚠ WARNING! *When assembling, screw down the fixing bolts (1). If necessary, replace the nuts and bolts only with GENUINE SPARE PARTS.*

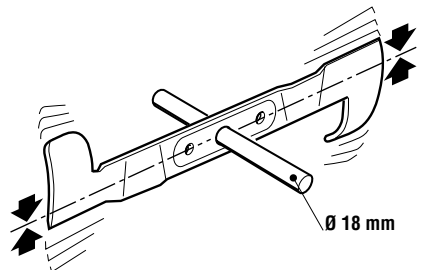

6.3.2 CUTTING DECK ALIGNMENT

The cutting deck should be properly set to obtain a good cut.

NOTE

To achieve good results from cutting, the front part should always be 5 - 6 mm lower than the rear.

1. Put the machine onto a flat surface and check the tyre pressure;
2. put 26 mm blocks (1) under the front edge of the deck and 32 mm blocks (2) under the rear edge, then put the lifting lever into position «1»;
3. loosen the nuts (3-5), the locknuts (4-6) on the right and left-hand side and the nuts (7 – 8), so that the deck is resting firmly on the blocks;
4. tighten the nut (3) and the locknut (4);
5. turn the nut (7) until the front part of the deck just begins to rise;
6. turn the nut (5) until the rear part of the deck just begins to rise and tighten the locknut (6);
7. check the front part and if necessary, turn the nut (7);
8. tighten the nut (8) on the pin (9).

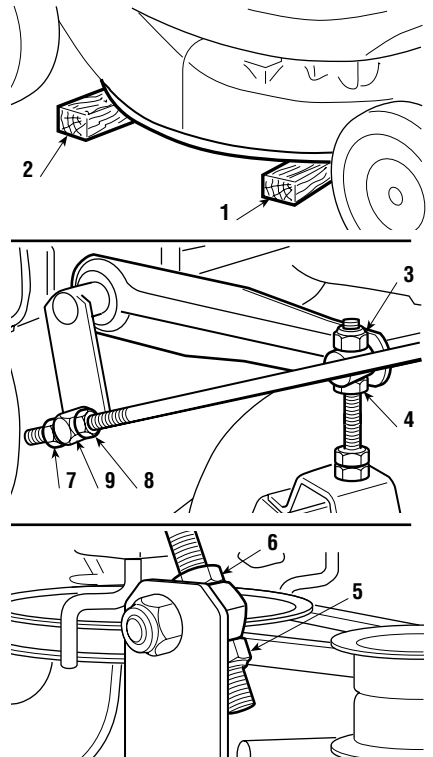

If you are unable to adjust the cutting deck properly, consult a Licensed Service Centre.

6.3.3 ADJUSTING THE ENGAGEMENT AND BRAKE OF THE BLADE

When you operate the lever to disengage the blade, this also brings the brake into operation for stopping the blade within few seconds.

If this is faulty, contact a Licensed Service Centre.

6.3.4 BRAKE ADJUSTMENT

If the braking distance lengthens, the brake will need adjusting. The adjustment will need to be made with the parking brake ENGAGED.

1. Remove the collector channel (1), which is fixed by a pin (2) and split pin (3);
2. turn the adjusting nut (4) (which is reached by taking off the engine cover) until there is a distance of 86-88 mm between the bracket (5) and the upper part of the lever (6).
3. refit the collector channel (1) and put the pin (2) and split pin (3) back in place.

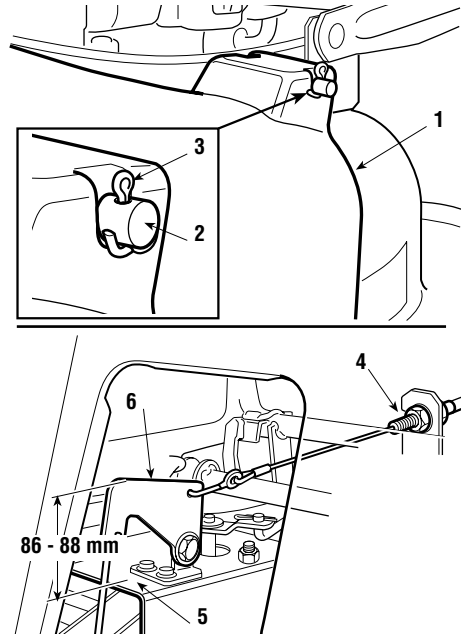

⚠ WARNING!

If the brake still does not work properly even after this adjustment, immediately contact the Licensed Service Centre. DO NOT ATTEMPT ANY OTHER WORK ON THE BRAKE THAN WHAT IS DESCRIBED HERE.

6.3.5 ADJUSTING THE TENSION OF THE DRIVE BELT

If you should notice that forward drive power has dropped, it will be necessary to adjust the spring of the stretcher. Make the adjustment with the parking brake DISENGAGED (to make sure that the machine does not move) and with the cutting deck in position «3».

1. Remove the collector channel (1), fastened by a pin (2) and the split pin (3);
2. check that the cap (4) of the engagement cable is fitted firmly in its correct position;
3. turn the nuts (5) until the spring (6) reaches a total length of 174 - 176 mm measured from the outer ends of the eyelets;

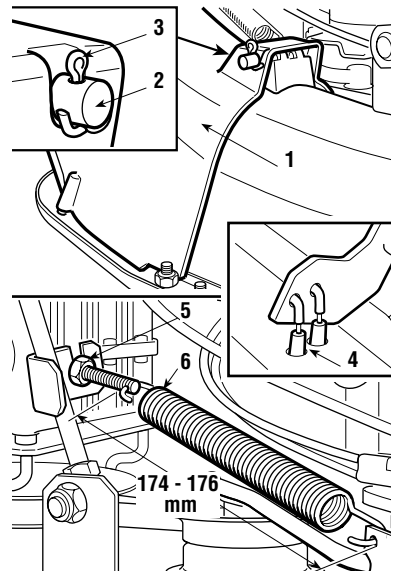

4. check that the spring (7) of the engagement cable is not too taut or too loose. Otherwise, turn the adjusting nut (8) until the spring reaches the right condition.
5. check the measurement of the spring (6) again;
6. refit the collector channel (1), and always put back the pin (2) and the split pin (3).

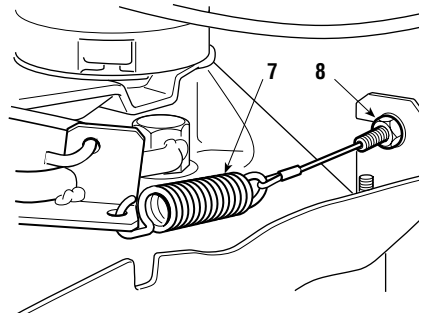

6.4 DISMANTLING AND REPLACEMENT

6.4.1 REPLACING WHEELS

1. Place the machine on a flat surface and put blocks under a load-bearing part of the frame on the side of the wheel to be changed;
2. using a screwdriver, remove the snap ring (1) and the washer (2);
3. pull out the wheel.

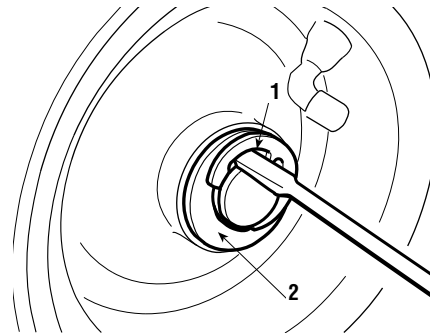

IMPORTANT *Smear some waterproof grease on the axle and after refitting the wheel, carefully refit the washer (2) and the snap ring (1).*

NOTE *Should you replace wheels or tyres, ensure that the right and left wheels are of the same rolling diameter, and check that cutting deck is adjusted properly to prevent an uneven cut.*

6.4.2 REPLACING AND REPAIRING TYRES

All puncture repairs or replacements will have to be carried out by a tyre repair expert in accordance with the methods for the kind of tyre used.

6.4.3 ELECTRIC AND PROTECTION SYSTEM

▶ **In the electric start models:**

- The electric system and the electronic card
- are protected by a fuse. When it blows the
- machine stops, so in this case:
-
- 1. tighten the two screws (1) that fasten the
- box (2) containing the card, and hold up
- the lower part to prevent it from falling;
- 2. remove the lid (3) and pull out the card
- (4) slightly;
- 3. replace the fuse (5) with another one of
- 6.3 A (delayed).
- 4. always put the lid (3) back on and refit
- the box (2) in its correct position.
-
-
-
-
-
-
-
-
-
-

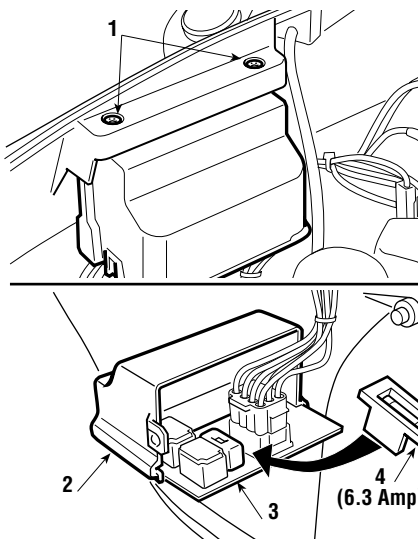

IMPORTANT

A blown fuse must always be replaced by one of the same type and ampere rating, and never with one of another rating.

- If you cannot find out why the fuse has blown, consult a Licensed Service
- Centre.

▶ **In the manual start models:**

- The electric system and the card are not protected by any fuses. If the safety
- system fails to work properly or there are engine problems due to the electric
- system, contact a Licensed Service Centre.

6.4.4 REPLACING THE BELT



The belt replacement must be carried out at a Licensed Service Centre.

NOTE

Replace the belts as soon as they show obvious signs of wear! ALWAYS USE GENUINE REPLACEMENT BELTS!

7. TROUBLESHOOTING

PROBLEM	LIKELY CAUSE	SOLUTION
<p>1. With the key on «START» the starter motor does not run</p>	<p>Electronic card blocked due to:</p> <ul style="list-style-type: none"> - flat battery or sulphated battery plates - fuse blown - bad earthing to the engine or the frame - earth connections of the microswitches disconnected - badly earthed starter motor - you are not ready for starting 	<p>Turn the key to «STOP» and look for the cause of the problem:</p> <ul style="list-style-type: none"> - recharge battery (➡ 6.2.5) - replace fuse (6.3 A - delayed) (➡ 6.4.3) - check connections of black earth leads - check connections - check earth connections - check that the conditions allowing the start are met (➡ 5.2.a)
<p>2. With the key on «START» the starter motor runs but the engine does not start</p>	<ul style="list-style-type: none"> - faulty fuel supply - faulty ignition 	<ul style="list-style-type: none"> - check the level in the tank (➡ 5.3.3) - check the wiring of the fuel open command - check fuel filter - check that spark plug caps are firmly fitted - check that the electrodes are clean and have the correct gap
<p>3. The engine stops</p>	<p>Electronic card blocked due to:</p> <ul style="list-style-type: none"> - earth connections of the microswitches disconnected - flat battery - badly connected battery (poor contact) - engine badly earthed 	<p>Turn the key to pos. «OFF» and look for the cause of the problem:</p> <ul style="list-style-type: none"> - check connections - recharge battery (➡ 6.2.5) - check connections (➡ 3.5) - check engine earth connection

PROBLEM	LIKELY CAUSE	SOLUTION
 4. The engine does not start	– earth connections of the microswitches disconnected	– check connections
	– you are not ready for starting	– check that the conditions allowing the start are met (☛ 5.2.a)
	– faulty fuel supply	– check the level in the tank (☛ 5.3.3) – check the wiring of the fuel open command – check the fuel filter
	– faulty ignition	– check that spark plug caps are firmly fitted – check that the electrodes are clean and have the correct gap
 5. The engine stops	– earth connections of the microswitches disconnected	– check connections
6. Starting is difficult or the engine runs erratically	– fault in carburation	– clean or replace the air filter – flush out the float chamber – empty fuel tank and refill with fresh fuel – check and, if necessary, replace fuel filter
7. Weak engine performance during cutting	– forward speed too high in relation to cutting height	– reduce the forward speed and/or raise the cutting deck (☛ 5.4.5)
8. Engine stops when blade is engaged	– you are not ready to engage the blade	– check that the safety requirements are met (☛ 5.2.b)

PROBLEM	LIKELY CAUSE	SOLUTION
9. Uneven cut and poor grass collection	– cutting deck not parallel to the ground	– check the tyre pressure (☛ 5.3.2) – realign the cutting deck to the ground (☛ 6.3.2)
	– blade cutting badly	– check that the blade is fitted properly (☛ 6.3.1) – sharpen or fit new blade (☛ 6.3.1)
	– forward speed too high compared to height of grass	– reduce forward speed and/or raise the cutting deck (☛ 5.4.5) – wait for the grass to dry
	– collector channel is blocked	– remove the grass-catcher and empty the collector channel (☛ 5.4.7)
	– cutting deck full of grass	– clean the cutting deck (☛ 5.4.10)
10. Unusual vibrations while working	– blade unbalanced	– balance or replace the blade if damaged (☛ 6.3.1)
	– blade loose	– check that the blade is fastened properly (☛ 6.3.1)
	– fixing bolts loose	– check and tighten all the fixing bolts of the engine and frame

If problems continue after having carried out these operations, contact a Licensed Service Centre.

⚠ WARNING!

Do not take on complicated repair work if you don't have the necessary equipment and the technical knowledge. The guarantee is automatically revoked and the manufacturer declines all responsibility for any bad repairs.

8. ACCESSORIES ON REQUEST

1. KIT FOR "MULCHING"

It finely chops the grass cuttings and leaves them on the lawn, instead of collecting them in the grass-catcher.

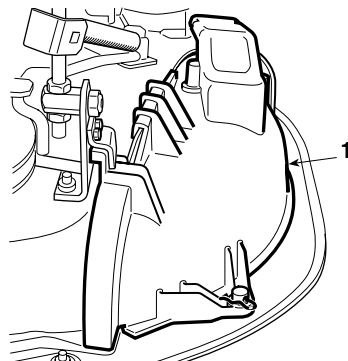

9. SPECIFICATIONS

Electrical system (▶ Only in the electric start models).....	12 V
Battery (▶ Only in the electric start models).....	7,2 Ah
Front tyres	11 x 4.00-4
Rear tyres	13 x 5.00-6
Front tyre pressure	1.8 bar
Rear tyre pressure	1.3 bar
Overall weight	from 106 to 115 kg
Forward speed (approximate) at 3000 min ⁻¹ :	
in 1st	2.5 km/h
in 2nd	4.0 km/h
in 3rd	8.0 km/h
in Reverse	3.5 km/h
Inside turning circle (minimum diameter of uncut grass)	1.5 m
Cutting height	3 ÷ 7.5 cm
Cutting height	62 cm
Grass-catcher capacity	140 litres

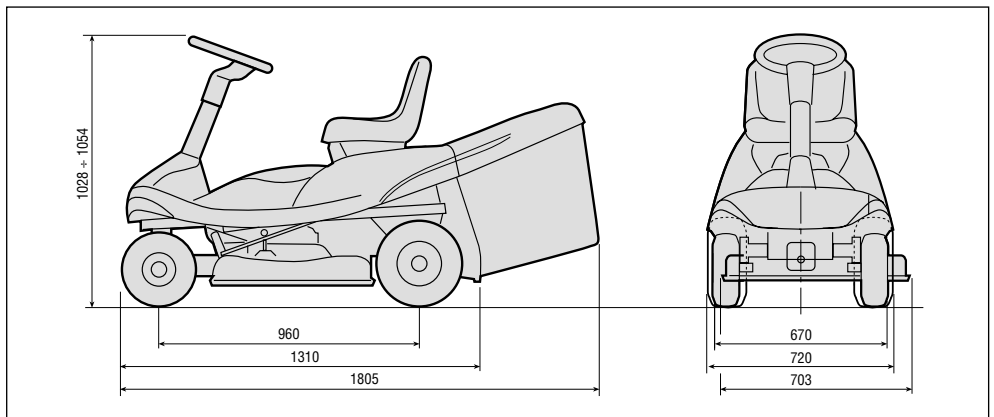



EMAK s.p.a. - Member of the YAMA group
42011 BAGNOLO IN PIANO (REGGIO EMILIA) ITALY
TEL. 0522 956611 - TELEFAX 0522 951555
EMAIL service@emak.it - INTERNET <http://www.emak.it>

